



INSTALLATION INSTRUCTIONS FOR WMSOU WALL MOUNTED LOOP POWERED ADDRESSABLE SOUNDERS.

MODELS

Non Isolation - **WMSOU-RR-P01** and **WMSOU-WW-P01**.
With Isolation - **WMSOU-RR-P02** and **WMSOU-WW-P02**.

GENERAL

The WMSOU range of sounders is designed to be connected to analogue addressable fire alarm systems. These sounders must only be connected to control panels that use a compatible proprietary analogue addressable communication protocol. These devices receive their power from the loop, and can be controlled via the communication protocol(s). The sounders have three volume levels and 32 tone sets. Models WMSOU-RR-P02 and WMSOU-WW-P02 include in built isolation providing short circuit protection of the loop.

Up to 159 addresses are available. These are selected via the two rotary selector switches. The 'tens' digits go from 0 to 150 (0 to F) and the 'units' from 0 to 9. See address settings on reverse.

Volume setting is selected by SW6 and SW7 of the 8 way DIP switch (see table 1). The appropriate tone set is selected by SW1 to 5 of the 8 way DIP switch (see table 2). The 2nd stage tone (related to the 1st stage tone) is controlled by the fire panel via the protocol.

SPECIFICATIONS

Signalling Line Supply Voltage (non isolation) 15 to 32VDC (24VDC typical)
Signalling Line Supply Voltage (isolation) 15 to 28VDC (24VDC typical)

Max current consumption (High Volume Tone 24 @24V) <6.81mA
Max Output Power (High Volume Tone1 @24V) 100dB(A) +/- 3dB

Operating temperature range -25 to +70°C
Relative humidity up to 95% - non condensing

Terminal Connections (See table)
Terminal Size 2.5mm² - maximum

IP Rating
With Low profile base IP24
With Waterproof base IP65

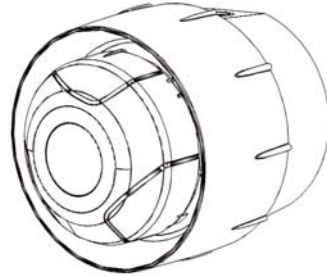
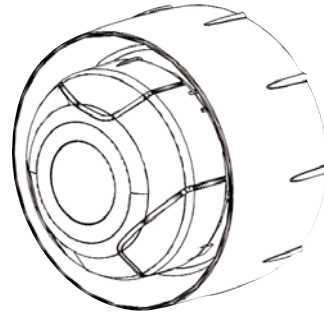

Terminal Description

Terminal	Function
T1	Negative
T2	Positive in
T3	Positive out
T4	N/C
T5	Shield

Table 1

SW6	SW7	Volume setting
OFF	OFF	HIGH
OFF	ON	MEDIUM
ON	OFF	LOW
ON	ON	LOW

BASES

Low Profile Base

Deep Base

Waterproof Base

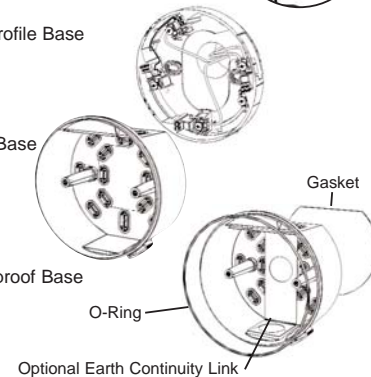

INSTALLATION

Affix sounder Base to a suitably flat wall.
Terminate the cable to the appropriate terminals.
Select the appropriate Tone and Volume settings via the DIP switch.
Locate the main assembly on to the base by rotating until it locks into place.
The low profile base can be screwed to the deep base if required using the two screws provided.

If the waterproof option is required then the wall gasket must be fitted behind the deep base, and the sealing o ring fitted after attaching the low profile base.

CONTINUITY SPRING

The sounder base incorporates a continuity spring between terminals 2 and 3. This allows the continuity of the field wiring to be checked without the need for the sounder to be present. Inserting the sounder will disengage the spring. Removing the sounder will close the loop.

ANTI TAMPER LOCK

The sounder base also includes a tamper resistance feature that when activated prevents removal of the unit without the use of a tool.

To activate this feature, carefully, using a pair of small pliers or similar remove the tab section in the wall of the sounder (as shown). A sprung section of the base will now snap into this cavity upon installation of the device. This prevents the device being turned to enable its release.

To remove the device once the tamper resistance feature has been activated, place a small bladed screwdriver into the small hole on the side of the unit and push the plastic lever into the hole, away from the sounder. This will allow the sounder to be rotated free of the plastic arm.
This feature is non-reversible.

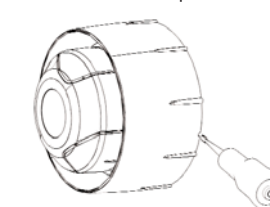
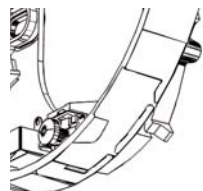
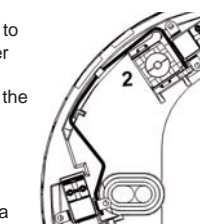
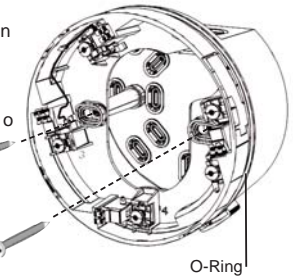

Sounder Tone Select DIP Switch configuration

Table 2

DIP setting O=Off/1=On SW 1,2,3,4,5	No	Pattern	Nominal Frequency	Switching Frequency	Description	Standard	2nd Stage Tone
0,0,0,0,0	1	Alternating	554/440	2Hz (100mS/400mS)	French Fire Sound AFNOR	NFS 32-001	7
1,0,0,0,0	2	Alternating	800/970	1Hz		BS5839 Pt1	8
0,1,0,0,0	3	Alternating	800/970	2Hz	Alternating tone telecoms	BS5839 Pt1 FP1063.1 Telecoms	8
1,1,0,0,0	4	Alternating	2400/2900	3Hz			10
0,0,1,0,0	5	Alternating	2500/3100	2Hz			10
1,0,1,0,0	6	Alternating	988/645	2Hz			8
0,1,1,0,0	7	Continuous	660		All Clear		1
1,1,1,0,0	8	Continuous	970			BS5839 Pt1	2
0,0,0,1,0	9	Continuous	1200				2
1,0,0,1,0	10	Continuous	2850		Banshee/Bedlam HF Continuous		4
0,1,0,1,0	11	Continuous	4000				5
1,1,0,1,0	12	Intermittent	660	0.05Hz 6.5s on, 13s off			7
0,0,1,1,0	13	Intermittent	660	0.277Hz 1.8s on, 1.8s off			7
1,0,1,1,0	14	Intermittent	660	3.33Hz 150mS on, 150mS off	Swedish Alarm Tone		7
0,1,1,1,0	15	Intermittent	970	0.8Hz 0.25s on, 1s off	intermittent Tone	BS5839 Pt1	8
1,1,1,1,0	16	Intermittent	970	1Hz 1s on, 1s off	Backup alarm HF & BS5839 Pt1	BS5839 Pt1	8

Sounder Output data, in accordance with EN54-3, is available on Document Ref: D 535.

DIMENSIONS

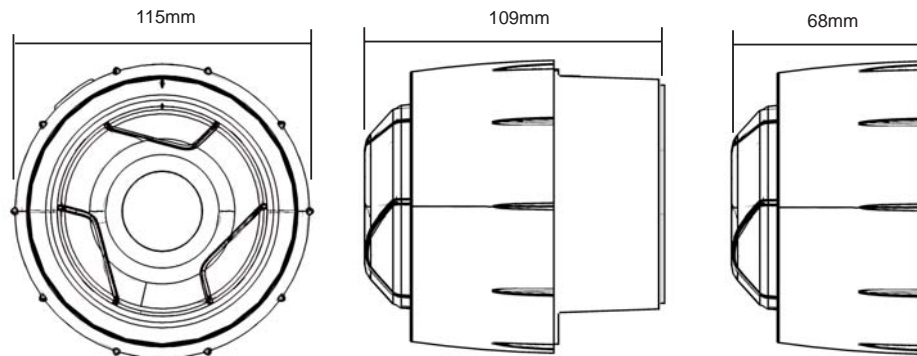

DIP setting O=Off/1=On SW 1,2,3,4,5	No	Pattern	Nominal Frequency	Switching Frequency	Description	Standard	2nd Stage Tone
0,0,0,0,1	17	Intermittent	2850	1Hz	Backup alarm HF & BS5839 Pt1 2nd Tone	BS5839 Pt1	10
1,0,0,0,1	18	Intermittent	970	1Hz 500mS on, 500mS off	ISO 8201 LF & BS5839 Pt1	BS5839 Pt1, ISO 8201	8
0,1,0,0,1	19	Intermittent	950	0.22Hz (0.5s on, 0.5s off)*3, 1.5s off			8
1,1,0,0,1	20	Intermittent	2850	4Hz 150mS on, 100mS off	Pelican Crossing		10
0,0,1,0,1	21	Sweep	400-1200	(0.5s on, 0.5s off)*3, 1.5s off			9
1,0,1,0,1	22	Sweep	1200 - 500	0.99Hz 1s on, 0.01s off	Evacuate, DIN tone & PFEER	DIN, PFEER	8
0,1,1,0,1	23	Sweep	2400 - 2850	7Hz	Fast Sweep Vds	Vds	10
1,1,1,0,1	24	Sweep	500 - 1200	0.5sec off 3.5sec on	Slow whoop evacuate Netherlands NEN 2575		8
0,0,0,1,1	25	Sweep	800 - 970	50Hz	LF buzz BS5839 Pt1	BS5839 Pt1	8
1,0,0,1,1	26	Sweep	800 - 970	7Hz	Fast sweep LF BS5839 Pt1	BS5839 Pt1	8
0,1,0,1,1	27	Sweep	800 - 970	1Hz	Medium sweep LF buzz BS5839 Pt1 Vds	BS5839 Pt1	8
1,1,0,1,1	28	Sweep	2400 - 2850	50Hz			10
0,0,1,1,1	29	Sweep	500 - 1000	7Hz			8
1,0,1,1,1	30	Sweep	500 - 1200 - 500	0.166Hz rise 1s, stable 4s, fall 1s			8
0,1,1,1,1	31	Sweep	800 - 1000	2Hz			8
1,1,1,1,1	32	Sweep	2400 - 2850	1Hz			10

ADDRESS SETTING

To set one of the 159 available addresses for the device use the two rotary selectors located alongside the dip switch unit.

The 'tens' digits go from 0 to 15 (0 to F) and the 'units' from 0 to 9.

- A = 10
- B = 11
- C = 12
- D = 13
- E = 14
- F = 15

