

This information is included with the M512ME module as a quick reference installation guide. Refer to the control panel manufacturer's installation manual for detailed system information. If the module will be installed in an existing operational system, inform the operator and local authority that the system will be temporarily out of service. Disconnect power to the control panel before installing the modules.

**NOTICE:** This manual should be left with the owner/user of this equipment.

## **GENERAL DESCRIPTION**

The M512ME conventional zone monitor module provides an interface between a zone of conventional 2-wire fire detectors and an intelligent signalling loop. The module monitors the conventional zone and transmits the state of the zone (NORMAL, OPEN/SHORT or ALARM ) to the panel. The M512ME features a power supply fault input T5. When the voltage at this terminal is pulled to ground, a fault signal is indicated at the panel.

The power for the conventional zone is provided either by an external power supply, or directly from the communication line. Use of the M512ME without an external power supply also results in more current being drawn from the communication loop. Please refer to the control panel installation manual for information on system design constraints.

When the power for the conventional zone is taken from an external power supply, the communication line is fully isolated from the conventional zone and from the power supply. The external power supply must have a battery backup feature if required by local codes of practice. System Sensor also recommends the use of a power supply with earth fault detection. The conventional zone current is limited to 60mA. A pair of break-off tabs is provided on the PCB (see Figure 3) to allow the current limit to be reduced. If the tabs on the PCB are broken, the maximum zone current is limited to 20mA.

The LED indicator can be latched on or returned to the normal mode by code command from the panel. The conventional detectors can be reset by command from the control panel. Convenient rotary decade switches are used to set the address of each module.

## **COMPATIBILITY REQUIREMENTS**

To ensure proper operation, these modules shall be connected to approved compatible system control panels only.

The M512ME zone monitor module is compatible with all System Sensor 2-wire conventional detectors when used with a resistive base. The module is also compatible with System Sensor conventional intrinsically safe detectors when used with MTL model 728 barrier or MTL model 3043 isolator. When an intrinsically safe system is used with the M512ME, a short-circuit on the detector side of the safety barrier will result in an alarm. Only a short on the *module* side of the safety barrier will result in a fault signal.

The M512ME can also be used to interface to the System Sensor 6424 beam detector (see Figure 6).

## **MOUNTING THE M512ME**

The M512ME module mounts directly to square electrical boxes as shown in Figure 2. The box must have a minimum depth of 2-1/8 inches. The SMB500 Surface-mounting box (available from System Sensor) is ideal for mounting the M512ME. Alternatively, up to 8 standard-size System Sensor modules (M512ME, M500ME, M500CHE or M500XE) can be mounted on the System Sensor MB500 module

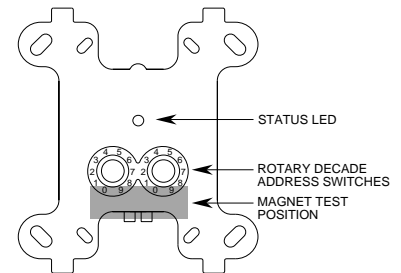

A78-2318-00

**FIGURE 1.**  
ZONE MONITOR MODULE  
CONTROLS AND INDICATORS

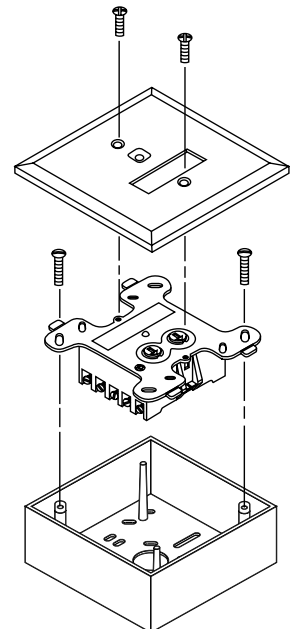

A78-2653-00

**FIGURE 2.**  
EXPLODED VIEW OF TYPICAL  
MODULE DETAILING MOUNTING  
ARRANGEMENT

panel. This allows easy connection and mounting in a standard 19 inch rack.

**WIRING**

NOTE: All wiring must conform to applicable local codes, ordinances and regulations.

1. Install module wiring in accordance with the job drawings and appropriate wiring diagrams (Figures 4 , 5 and 6).
2. Set the address on the module per job drawings.
3. Secure the module to the electrical box (supplied by installer), as shown in Figure 2.
4. Perform steps one, two, and three for all modules.

NOTE: Terminal T9 is not internally connected, but may be used to aid field wiring if necessary.

**MAGNET TEST**

The module can be tested with a test magnet available from System Sensor (M02-04-00, see Figure 1). The magnet test checks the module electronics and connections to the control panel. Each detection device connected to the module must be tested independently.

**SPECIFICATIONS**

Communication Loop Supply Voltage:	15 - 32V
Communication Loop Standby Current ( External PSU, No communication):	200 $\mu$ A (Max.)
Communication Loop Standby Current ( External PSU, Communication every 5 seconds):	300 $\mu$ A (Max.)
Communication Loop Standby Current ( LED on):	5.1mA (Max.)
Maximum Conventional Zone Voltage:	25.5V @ 0mA
Conventional Zone Current Limit (PC Board Tabs removed):	20mA (Max.)
Conventional Zone Current Limit (PC Board Tabs not removed):	60mA (Max.)
Reset Voltage (Terminal B):	0.4V (Max.) @ 15mA
Maximum Conventional Zone Standby Current (No External PSU, comm. line @ 24V):	9mA
End-of-Line Resistor Value:	3.9k $\omega$ , 5%
External Power Supply Voltage:	18 - 32V
Maximum Line Impedance, Conventional Zone:	100 $\omega$
Power Supply Fault Input (Active Low):	0.2V (Max.)

**Environmental Specifications**

Temperature Rating:	-10°C - 60°C
Relative Humidity (no condensation):	10% - 93%

**Mechanical Specifications**

Wire diameter for screw terminals:	1 - 2mm
Box dimensions (mm):	32 x 70 x 70
Mounting plate dimensions (mm):	121 x 107
Weight:	140g

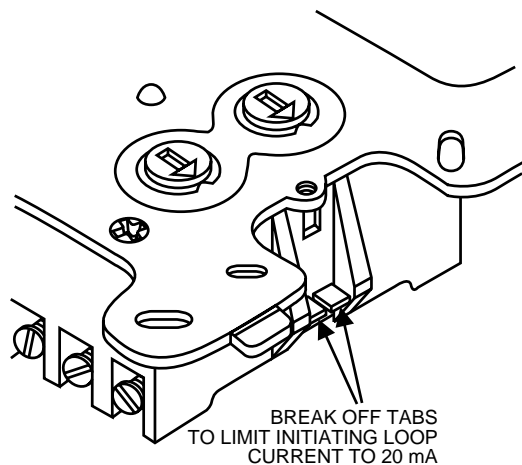

A78-1953-03

FIGURE 3. USE OF BREAK-OFF TABS TO CONTROL CURRENT-LIMITING

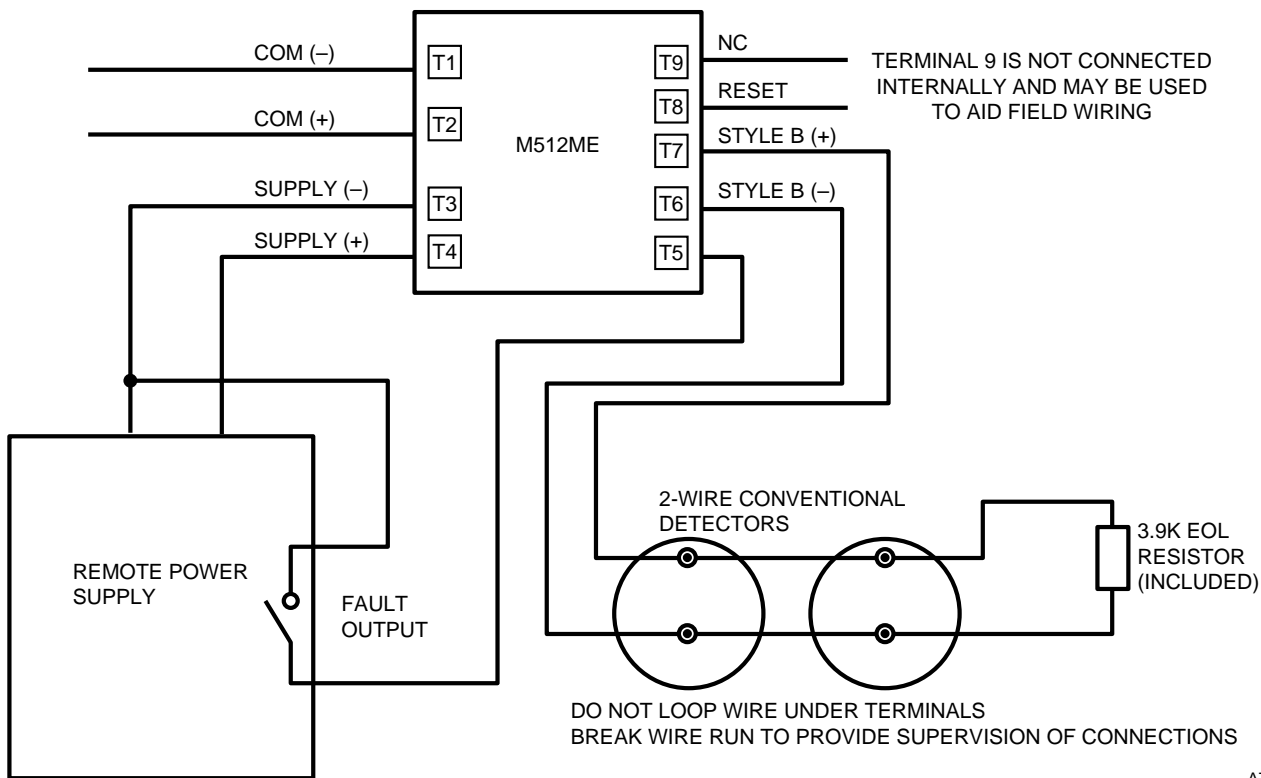

A78-2655-00

FIGURE 4. WIRING TO ZONE OF 2-WIRE CONVENTIONAL DETECTORS, USING EXTERNAL POWER SUPPLY

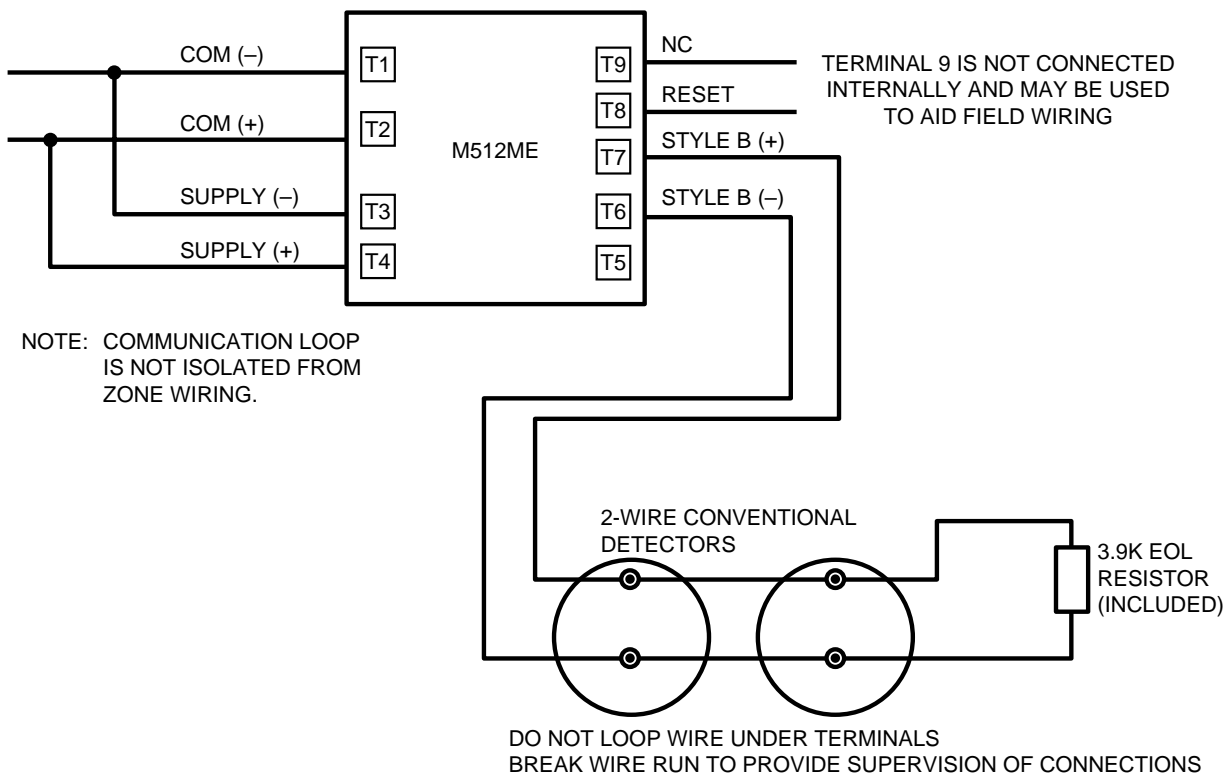

A78-2656-00

FIGURE 5. WIRING TO ZONE OF 2-WIRE CONVENTIONAL DETECTORS WITHOUT EXTERNAL POWER SUPPLY

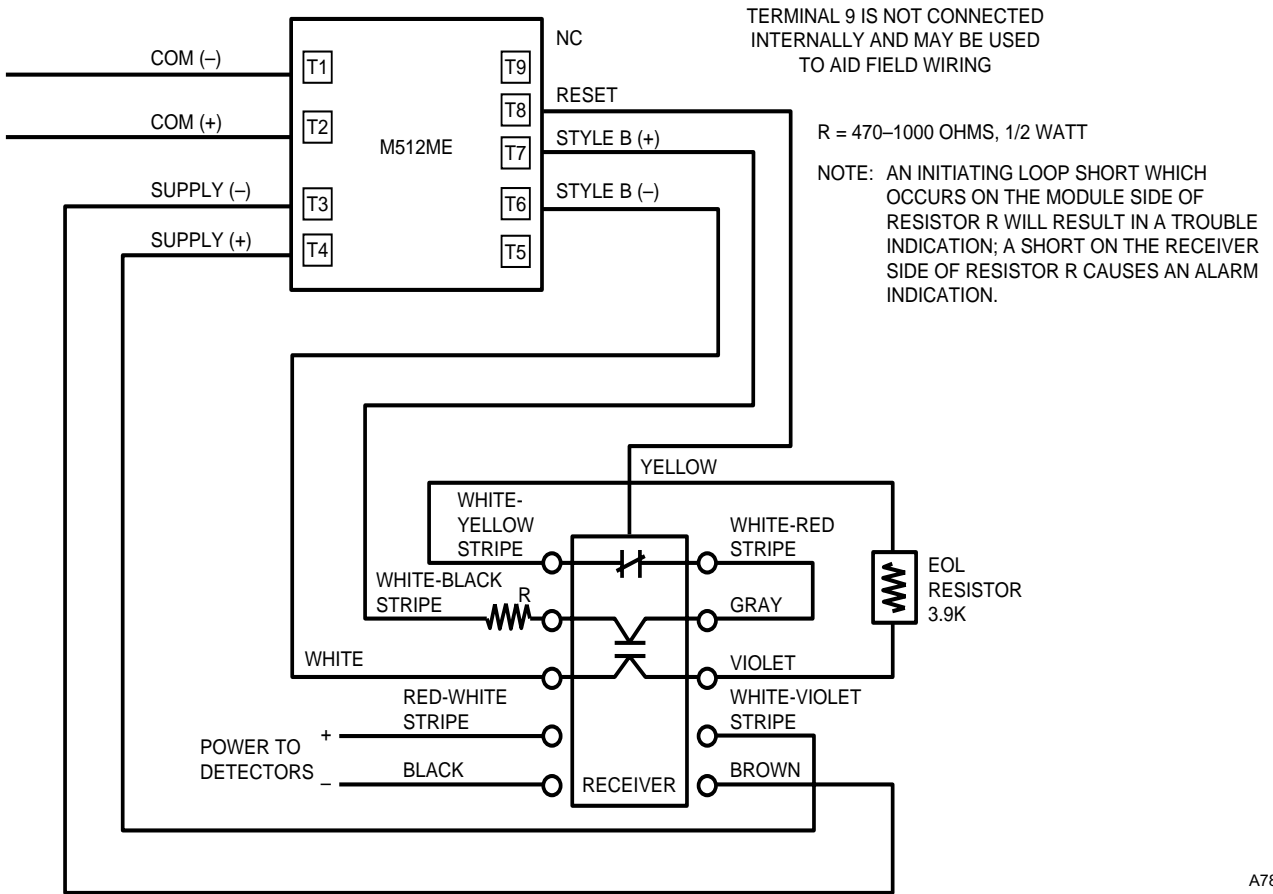

A78-2657-00

FIGURE 6. WIRING TO A SYSTEM SENSOR 6424 BEAM DETECTOR